

MUNCKHOF



“U” TRIMMERS

BLADE DESIGN

The Carbon steel advantage

Trimmer blades are not all manufactured the same. Blades used on Munckhof Trimmers, Hedgers and Pruners are among the best in the industry. This high quality is achieved by using superior material and taking extra care in manufacturing.

Our blades are made of abrasion-resistant, high-carbon, nickel chrome-alloy steel. This steel (commonly used for Mining and rock abrasion applications) has the hardness to be extremely resistant to wear and breakage. Unlike the lower-carbon blades used by many manufacturers.

Munckhof blades will withstand hard objects with no chipping while remaining ductile enough to non work harden and crack. Our blades have a Rockwell Hardness of ~47C. Which results in a surface that is within the goldilocks zone between pre mature wear and being overly brittle. The result is a better cutting job and longer blade life.

In providing a quality blade, the attention given to the manufacturing process is as important as using high-quality material. Munckhof blades are precision manufactured. The process includes:

- Laser cutting to an angled shape so that the blade cuts over the vine rather than chopping straight against the canopy wall.

- precision milling at each end for a smooth, sharp cutting surface.

- Flattening to ensure a perfectly straight and balanced cut.

- Finally the blades are inspected. This ensures that only the best blades are used.

During assembly, the blades are placed on the trimmer so that the beveled edge faces away from the canopy. This is because the straight edge of the blade will leave a cleaner cut against the canopy side of the machine, leaving less damage on the plant.

HEAD DESIGN

Gravity Centering

U Trimmers use a unique gravity centering head that allows for resistance based dampening and centering of the trimmer, used in conjunction with our nylon guides, it is the most simple and effective means for tracking a U Trimmer head, with no complex parts or control systems.

Because the friction brakes are adjustable, the resistance can be altered to accomodate different terrains or operator preferances.

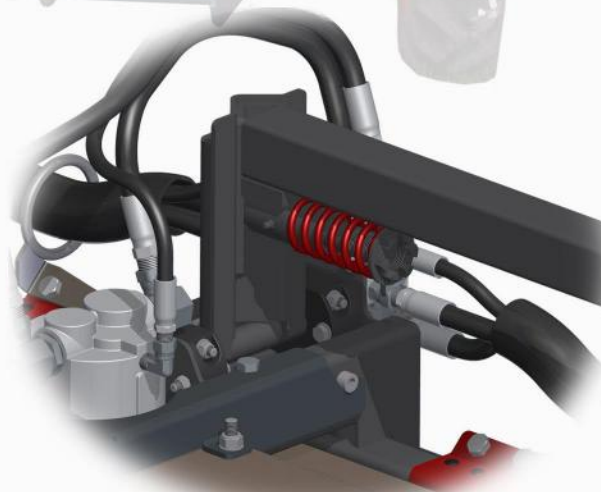

BELT DRIVE

V Belt technology

V Belts are used for the drive system in the Munckhof line. Also known as a friction drive, the V belt offers many advantages.

- V belts require no maintainace and are lubrication free.

- By employing a modular chain, belts are kept shorter and can transfer more power, also forces are distributed evenly over the blade housing.

- Belts sizes are standard, and readily available at local supply shops.

- If a blade contacts a post or immovable object, slipping can occur, preventing machine damage or breakage.

BODY STRUCTURE

Unibody Strength

The Trimmer frame is constructed of a two piece, frame and cover unibody design. This allows for a ridgid structure that is lightweight, and easy to access for maintainence and repair.

- By incorproating sloted openings for the blade housings, the cover can be slid back without having to remove the blade housings, allowing open access to the belt drive system with only minutes of work

- Average weight of an "U" trimmer head is only 340 lbs, allowing for installation on lighter tractors, and use in terrain where mechanical trimming may not have been an option before.

DEPENDABILITY

All the implements in the Munckhof line of vineyard equipment are designed, tested and manufactured at our facility in Oliver British Columbia. Because we are a North American manufacturer we deliver equipment that is designed to work in North American plantations. We are able to control every step of the production process and each machine is wet tested before it leaves our factory.

In your owners manual, universal language is used to describe all Hydraulics, bearings and belting. Because we use standard SAE components, parts can be obtained through local sources, greatly reducing downtime.

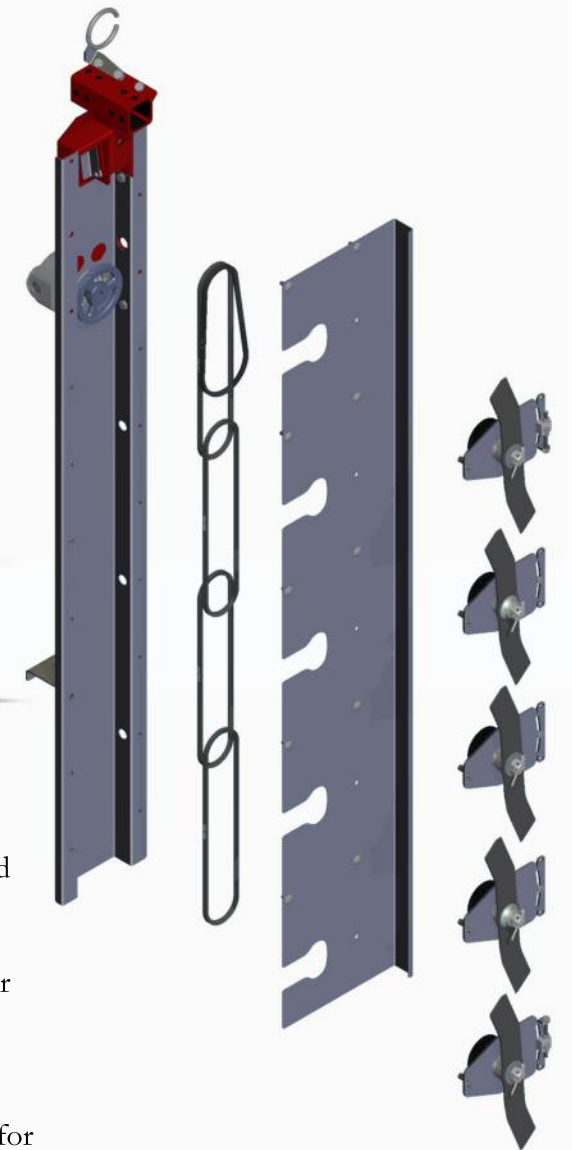

MOUNTING

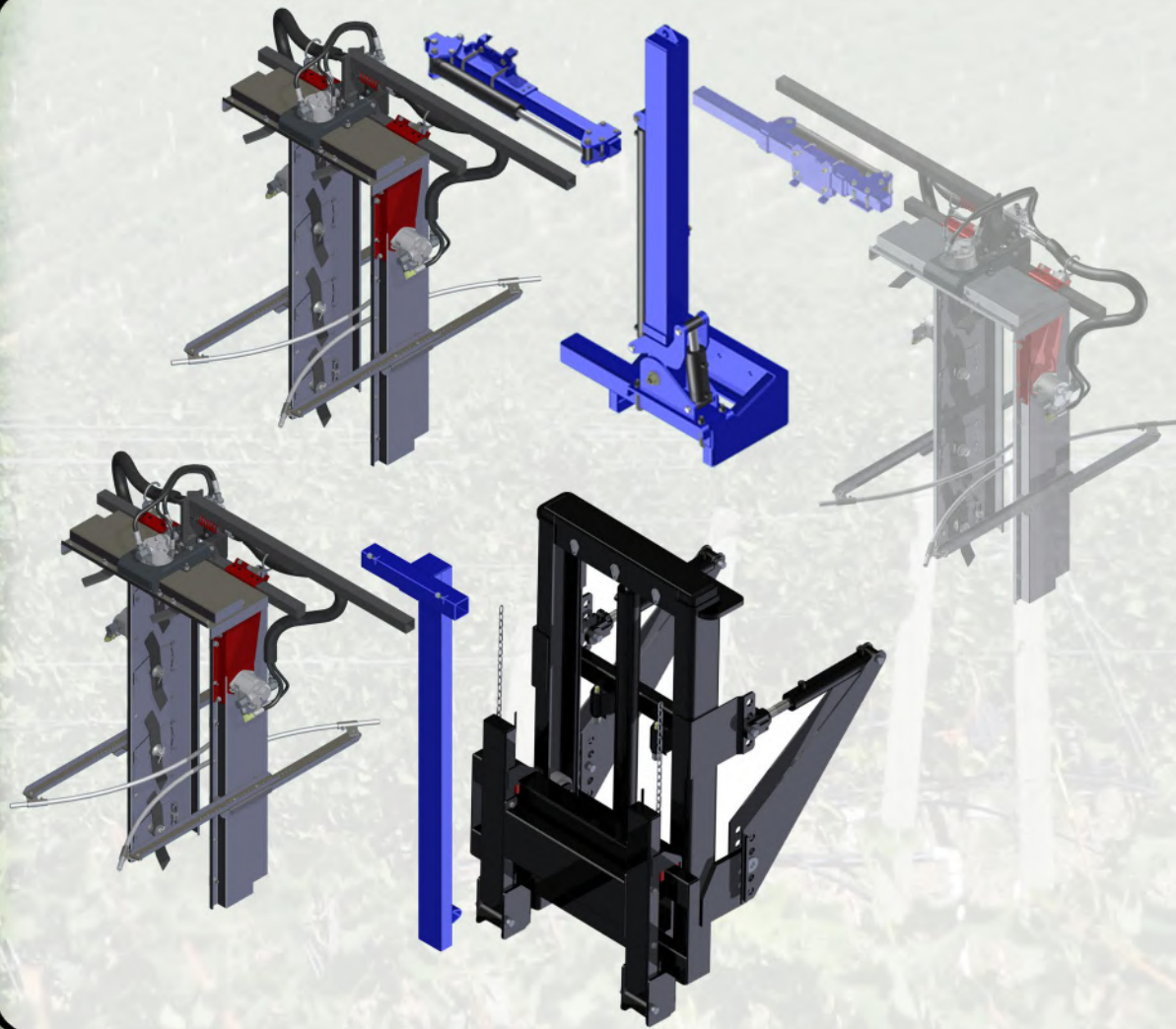

The Vine Trimmer is designed to be fitted seamlessly with both the Munckhof Universal post mount and the Munckhof vertical bin lift using the attachment brackets pictured. Installation is made simple by the use of our attachment brackets offering solid attach or optional hydraulic sideshift.

The Munckhof Universal post is an excellent tool for mounting not only the Trimmer head, but any front mounted tool in the Munckhof line. This gives the operator better versatility and saves costs.

The post has a hydraulic adjustment of 36 inches in height, and can tilt 16 degrees side to side. It also allows for 17 inches of static side placement to ensure proper positioning in the field.

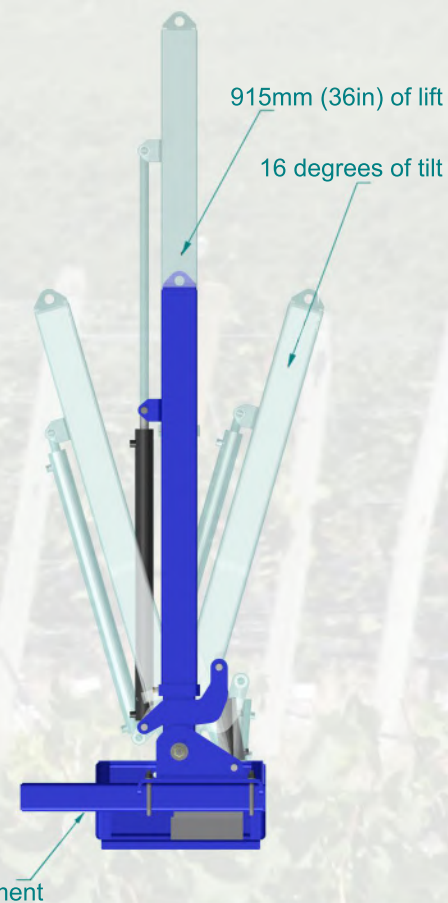

Supplemental hydraulic options are also available to further ease the use of our machines, we offer two types;

The 12VDC electric/hydraulic power pack is a self-contained pump and reservoir. It utilizes the tractors electric power system to generate hydraulic flow capable of operating the lifting and tilting operations of the post.

The hydraulic splitter block is a valve system. Utilizing the tractors hydraulic power, it can split a single hydraulic inlet into multiple outlets capable of operating all the functions of the post including the Trimmer head (presuming a sufficient hydraulic supply)



TRIMMER SPECS

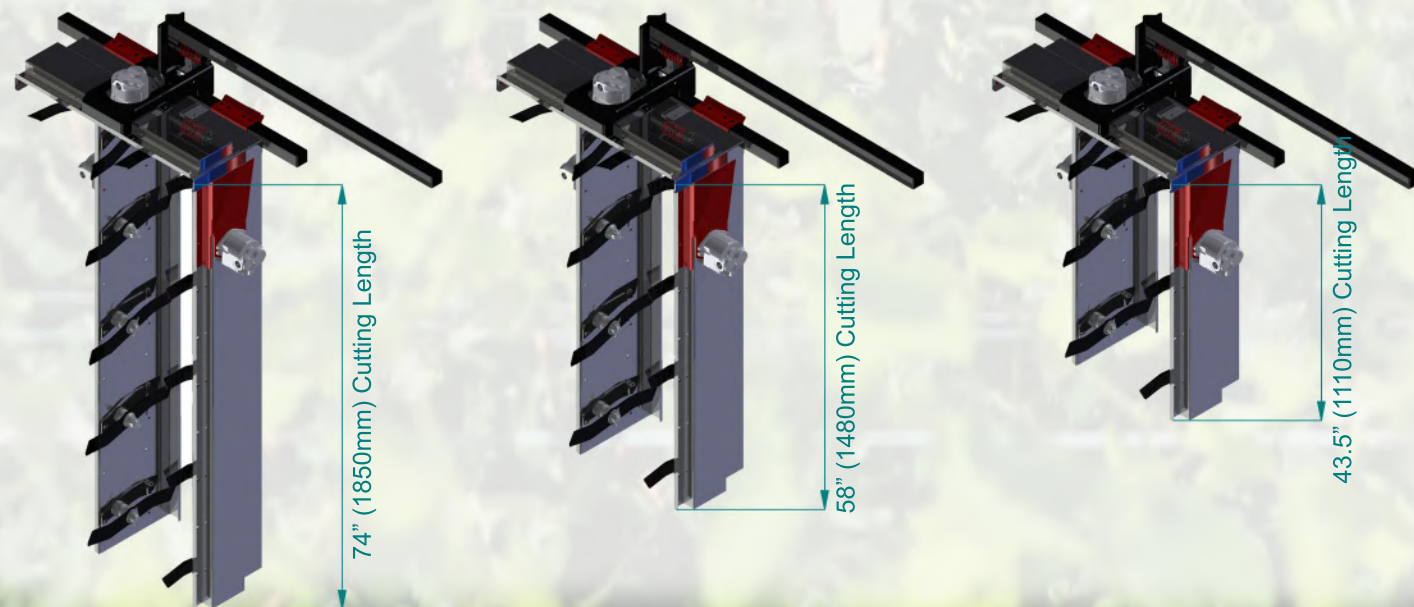

The active cutting length of the trimmer is determined by the amount of vertical blades are on the model. Cutting lengths of 74", 58", and 43.5" are standard.

Also adjustable is the opening width and angle of the sides, each side is independantly able to slide and "wing" out to the operators desired specification.

The nylon centering bars are also able to be positioned over a blade at any position desired by the operator



Munckhof Manufacturing

www.munckhof.com

Box 308
Oliver, British Columbia
VOH 1T0

Tel: 250-498-4426
Fax: 250-498-4460
Email: office@munckhof.com



MUNCKHOF

Your **Munckhof** dealer,